

Green Drain Professional -hajulukko Asennus- ja siivousohjeet



Green Drain -hajulukko lattiakaivoon

Hajulukon asennus lattiakaivoon

Huom! Ennen asennusta varmista, että hajulukon koko on oikea.

1. Poista ritilä ja mahdollinen vesilukko.

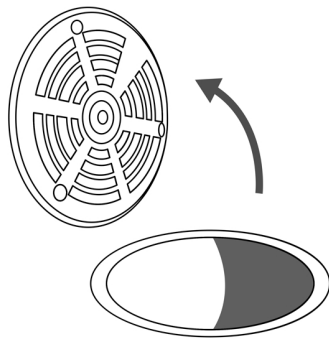

2. Paina hajulukko viemäriputkeen siten, että se on samalla tasolla yläreunan kanssa.

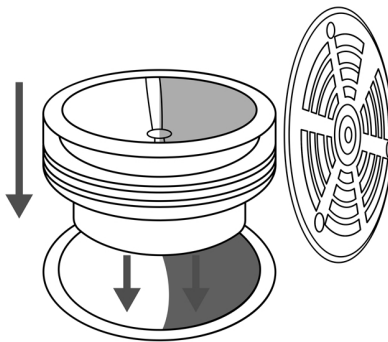

3. Sulje ritilä.

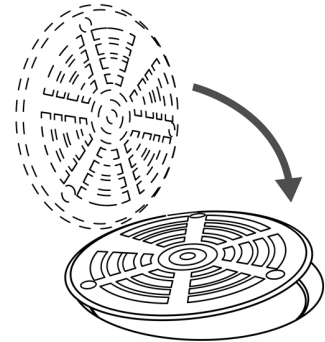

Siivousohje

1. Poista ja pese ritilä.
2. Nosta hajulukko pois lattiakaivosta.
3. Puhdista lattiakaivo.
4. Puhdista hajulukko pehmeällä liinalla ja pH-neutraalilla pesuaineella, joka ei kuluta tuotteen pintaa.
5. Asenna hajulukko ja ritilä takaisin paikoilleen.



Siivoussuositus:

Kiireiset suurien kävijämäärien kohteet, kuten huoltoasemat ja kauppakeskukset joka kuukausi. Varastot ja vähemmällä käytöllä olevat tilat 6-12 kuukauden välein.



Laatuvaatimuksena erinomaisuus.

Novosan Oy | Tikkurikuja 1 (2. krs), 00750 Helsinki | novosan.fi

Julkaisupäivämäärä 29.8.

Versio: 02/2023

Ohjeen laatija Green Drain Europe

Green Drain Professional Installation & cleaning instructions



Green Drain - trap seal for floor drains

Installation

To install Green Drains into the inside of the floor drain strainers, remove the grate and place the **appropriate size** Green Drain product into the inside of the throat of the strainer.

1. Remove grate and possible water trap.

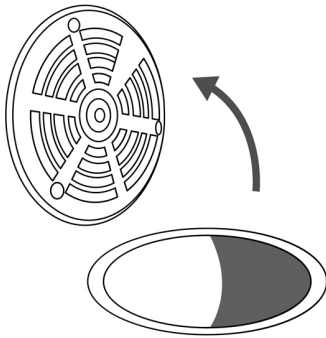

2. Press the Green Drain trap into the drain pipe so that it is in the same level with the top edge of the pipe.

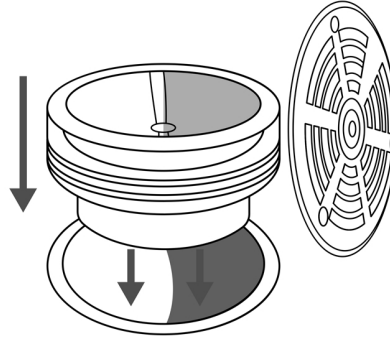

3. Close grate.

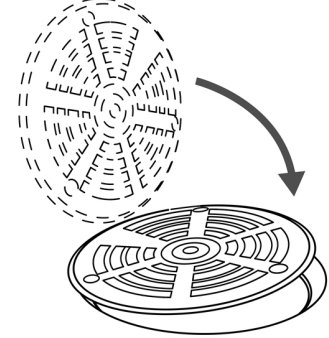

Cleaning instructions for the floor drain trap:

1. Remove and wash the grate.
2. Lift the trap out of the floor drain.
3. Clean the floor drain.
4. Clean the trap with a soft cloth and a pH-neutral cleaning agent that won't damage the surface of the product.
5. Reinstall the trap and grate back in place.



Cleaning recommendation:

Busy destinations with high visitor numbers, such as gas stations and shopping malls, once a month.
Storage areas and spaces with less frequent use every 6-12 months.



We never compromise on quality.

Novosan Oy | Tikkurikuja 1 (2. krs), 00750 Helsinki, Finland | novosan.fi

Date of production: 29.8.

Version: 02/2023

Original version Green Drain Europe